



GTS-65 / GTS-80

Shrink sleeve products for girth-weld protection of elevated operating temperature pipelines

Canusa-CPS is a leading manufacturer of specialty pipeline coatings which, for over 30 years, have been used for sealing and corrosion protection of pipeline joints and other substrates. Canusa high performance products are manufactured to the highest quality standards and are available in a number of configurations to accommodate your specific project applications.

Product Description

The GTS-65 & GTS-80 systems provide superior corrosion protection and excellent bonding on pipelines operating onshore up to 65°C & 80°C respectively. GTS-65 and GTS-80 have been designed with a unique adhesive technology that remains "open" longer than traditional adhesives. Also, special surface active agents allow bonding to lower surface energy coatings (such as polypropylene). As a result, lower preheats are required and superior bonding to PE, PP and FBE surfaces is achieved.

Features & Benefits

Superior Force Cured Epoxy Method

Canusa's proven method of force curing the epoxy primer to the steel allows the installer to "pre-inspect" the joint prior to sleeve application. The epoxy will not be displaced during the aligning and shrinking stages of the sleeve installation. This provides the assurance that the pipe is fully protected. Canusa's epoxy primer can be applied to an even, nominal 6 mil thickness for maximum corrosion protection.

Unique Adhesive Technology

Canusa's unique adhesive technology allows for lower installation pre-heats and superior bonding to PE, PP and FBE coatings. The adhesive has been formulated to bond directly to the main line coating; epoxy is applied to the steel only. The result is a superior bond to the substrate, easier application and significant cost savings.



Flexible Installation

GTS-65 and GTS-80 can be used as a 2-layer or 3-layer sleeve system at the same low pre-heat. For added flexibility, CanusaWrap bulk rolls are also available. Consult your Canusa representative to review your specific project requirements.

Long Term Corrosion Protection

GTS-65 and GTS-80 sleeves provide superior corrosion protection because of the high performance system approach. This combination provides a protective coating with the structural integrity of a seamless tube, providing excellent resistance to cathodic disbondment and excellent durability against abrasion and chemical attack. The result is effective, long term protection against corrosion.

Saves Time & Money

Time is saved in three ways; lower pre-heat means less time heating; epoxy on the steel only, means less time applying the epoxy; and the pre-attached closure means less time handling, positioning and installing the sleeve. The overall system minimizes installation time and labour costs while promoting high production rates.

Applications



Oil & Gas



Offshore Pipelines



Polypropylene

Configurations



Wrapid Sleeve™



CanusaWrap™



2-Layer



3-Layer

Pipe Sizes



55-1520 (2"-60")

Temperature Range



Up to 80°C (176°F)

Approvals



SNAM, Gaz de france, Trans Canada, Gazprom

GTS-65/GTS-80

Global Transmission Sleeve

Product Selection Guide

Choose your sleeve based on Operating Temperature and Characteristics listed below.

Sleeve Operating Characteristics	Celsius	Fahrenheit	GTS-65	GTS-80
	Pipeline Operating Temp.	200°	392°	
Minimum Installation Temp.	175°	347°		
Resistance to Circumferential Forces	125°	257°		
Resistance to Soil Stress	100°	212°		
Resistance to Axial Pipe Movement	75°	167°		
Main Line Coating Compatibility	50°	122°		
			65 (150) 90 (195) excellent excellent excellent	80 (175) 110 (230) excellent excellent excellent
			FBE, PE, HPCC, PP	FBE, PE, HPCC, PP

Epoxy Primer Information

GTS-65 and 80 (3-layer) require epoxy on the cut-back area and 10 mm (0.5") onto the adjacent pipe coating.

Epoxy Primer Kits

This kit includes measured quantities of base resin and cure, a stirring stick, applicator pad or roller and gloves. The kit contains sufficient primer for up to 1 square meter (10 sq. ft) of coverage. For example: 1 kit is sufficient for a 915mm (36") diameter pipe with a 300mm (12") total cutback.

Typical Primer Coverage
Joints per US gallon assuming 300mm (12") total cutback and 150µm (0.006") coating thickness

Pipe diameter joints/mm in US gallon

170	6.6	130
230	8.6	97
280	10¾	78
315	12¾	70
400	16	60
450	18	55
500	20	43
610	24	35
760	30	28
915	36	23
1060	42	20
1220	48	18
1422	56	15
1525	60	14

Bulk Epoxy Primer

Bulk epoxy components must be ordered separately. The mixing ratio for the E primer is 4 parts base, 1 part cure by volume, and 6.3 parts base, 1 part cure by weight. Pumps are available to facilitate mixing operation. Average coverage for bulk primers is 20 square meters per U.S. gallon, (220 sq. ft / U.S. gallon).

Epoxy Properties

Pot life @ 23°C (73°F)	20 minutes
Typical epoxy coated thickness	4 - 6 mils
Shelf Life @ 23°C, out of sunlight	3 years

Typical Product Properties

Adhesive	Test Standard	Unit	GTS-65	GTS-80
Softening point	ASTM E28	°C (°F)	94 (201)	124 (255)
Lap shear	DIN 30 672	N/cm ²	245	365
Backing				
Specific gravity	ASTM D792		0.93	0.94
Tensile strength	ASTM D638	MPa (psi)	24 (3480)	22 (3150)
Elongation	ASTM D638	%	700	500
Hardness	ASTM D2240	Shore D	50	55
Abrasion resistance	ASTM D1044	mg	35	30
Volume Resistivity	ASTM D257	ohm-cm	10 ¹⁷	2.5 x 10 ¹⁸
Dielectric Voltage Brkdw	ASTM D149	kV/mm	27	39
Sleeve				
Impact	DIN 30 672	class C	pass	pass
Indentation	DIN 30 672	class C	pass	pass
Peel	ASTM D1000	N/cm (pli)	120 (70) **	45 (26)
Peel	DIN 30 672	N/cm (pli)	86 (50) **	55 (32)
Cathodic Disbondment	ASTM G8	mm rad	3	3
Water Absorption	ASTM D570	%	0.05	0.05
Low Temp. Flexibility	ASTM D2671-C	°C (°F)	>-32 (-26)	>-20 (-4)
Fully Recovered T Thickness		mm (mils)	1.8 (71)	1.8 (71)
Fully Recovered L Thickness		mm (mils)	2.5 (99)	2.5 (99)
Fully Recovered S Thickness		mm (mils)	3.4 (134)	3.4 (134)

**force result of backing elongation during peeling due to superior bond strength

How To Order¹:

Dimensions & Ordering Info	Ordering Options - Global Transmission Sleeve		
	T Thickness	L Thickness	S Thickness
GTS-65 915-450 BK/T	T	L	S
Thickness	BK-Black		
Colour	300, 450, 600, 900mm (12", 18", 24", 36")		
Sleeve Width	55-500mm (2"-20")		
Pipe Size	55 - 1525 mm (2" - 60")		
Primer	Canusa "E" Epoxy (Optional)		
Adhesive (min. thickness as supplied)	0.8 mm (32 mils)	1.1 mm (45 mils)	1.5 mm (60 mils)
Backing (min. thickness as supplied)	0.63 mm (25mils)	0.76 mm (30mils)	1.0 mm (40mils)
Configuration	GTS-65 - 65°C (149°F)	GTS-80 - 80°C (176°F)	

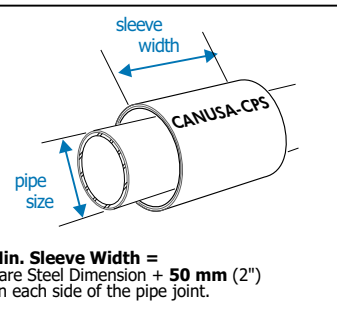

The above represent standard Wrapid Sleeve™ ordering options. Consult your Canusa representative for any unique project requirements.

¹ For CanusaWrap™ bulk rolls, consult you Canusa representative. GTS-65 requires CLW closures, whereas GTS-80 requires CLH closures.



A SHAWCOR COMPANY

Canada

CANUSA-CPS
a division of SHAWCOR LTD.
25 Bethridge Road
Rexdale, Ontario
M9W 1M7,
Canada
Tel: +1 (416) 743-7111
Fax: +1 (416) 743-5927

U.S.A./Latin America

CANUSA-CPS
a division of SHAWCOR INC.
2408 Timberloch Place
Building C-8
The Woodlands, Texas
77380, U.S.A.
Tel: +1 (281) 367-8866
Fax: +1 (281) 367-4304

Europe/Middle East

CANUSA-CPS
a division of Canusa Systems Ltd.
Unit 3, Sterling Park
Gatwick Road
Crawley, West Sussex
England RH10 9QT
Tel: +44 (1293) 541254
Fax: +44 (1293) 541777

Asia/Pacific

CANUSA-CPS
BrederoShaw (S) Pte Ltd
101 Thomson Road
#17-01/02, United Square
Singapore
307591
Tel +65-6732-2355
Fax +65-6732-9073